

# SR23

## COSHH essentials for service and retail

# Degreasing with solvents (low volatility, small scale work)

## Control approach S

### Harm via skin or eye contact



This information will help employers (including the self-employed and franchisees) comply with the Control of Substances Hazardous to Health Regulations 2002 (COSHH), as amended, to control exposure and protect workers' health.

It is also useful for trade union safety representatives.

This sheet describes good practice using general ventilation.

It covers the points you need to follow to reduce exposure to an adequate level.

It is important to follow all the points, or use equally effective measures.

This sheet does not apply to vapour degreasing.

Look at the safety data sheet for more information.

#### Main points

- Select only low-volatility, low toxicity solvents (boiling point above 150°C).
- Solvents may cause skin irritation and used oils may cause skin cancer.
- Check that all the controls in this sheet are being used properly.

- #### Access and premises
- ✓ Provide good washing facilities.

#### Equipment

- ✓ Provide protective gloves.
- ✓ Keep the workplace well ventilated - at least 10 air changes per hour with a through draught.
- ✓ Use a cleaning station (see illustration) that dispenses the minimum amount of low volatility solvent and stores waste solvent.
- ✓ If cleaning machinery in place, use non-spill dispensers and cleaning tools.

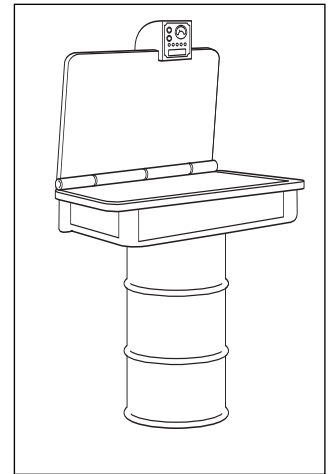

#### Personal protective equipment (PPE)

- ✓ Follow the instructions on product labels.
- ✓ Ask your supplier to help you get the right PPE.
- ✓ You may need respiratory protective equipment (RPE) for maintaining and cleaning the degreaser. Seek advice from your RPE supplier.
- ✓ Provide coveralls to protect skin from contamination.
- ✓ Provide chemical protective gloves for manual degreasing. Don't use gloves with a knitted liner.
- ✓ Unless you can show that gloves are not contaminated inside, throw them away at the end of the day's work.
- ✓ Skin creams are important for skin protection and help in washing contamination from the skin. These are not 'barrier creams'. After work creams help to replace skin oils.

**Caution: Workers must not take work clothing home for washing. Use a contract laundry.**

#### Procedures

- ✓ Store products securely in a cool, dry, dark place, capable of keeping in spills. Don't store far more than you need.

**Caution: Never pour waste solvent down the drain. Collect it for recycling.**

---

### Special Care

- ✓ Contact with solvent can lead to skin soreness and itching, rashes, blistering (dermatitis). Some can also damage the eyes.
- ✓ Waste engine oil may cause skin cancer. Never keep oily rags in your pocket.

### Maintenance, examination and testing

- ✓ Follow instructions in maintenance manuals - keep equipment in effective and efficient working order.
- ✓ At least once a week, look for signs of damage.

### Health monitoring

- ✓ Ask your workers to check their skin for dryness or soreness every six months. If these effects appear, check the proper use of skin creams and PPE.

### Cleaning and housekeeping

- ✓ Keep the work area clean.
- ✓ Clear up spills promptly. Provide granules to absorb spills, and a lidded bin kept outside in a secure place to store this waste for disposal.
- ✓ Dispose of hazardous waste through a specialist contractor.

### Training and supervision

- ✓ Tell workers about the risks of using the product - see products labels or Section 15 of the safety data sheet.
- ✓ Where you have to use strong hand cleansers, train workers to wash off the residues with soap and water.
- ✓ If products can cause skin or eye damage, plan how to give first aid.
- ✓ Working in the right way and using the controls correctly is important for exposure control. Train and supervise workers. See sheet SR0.

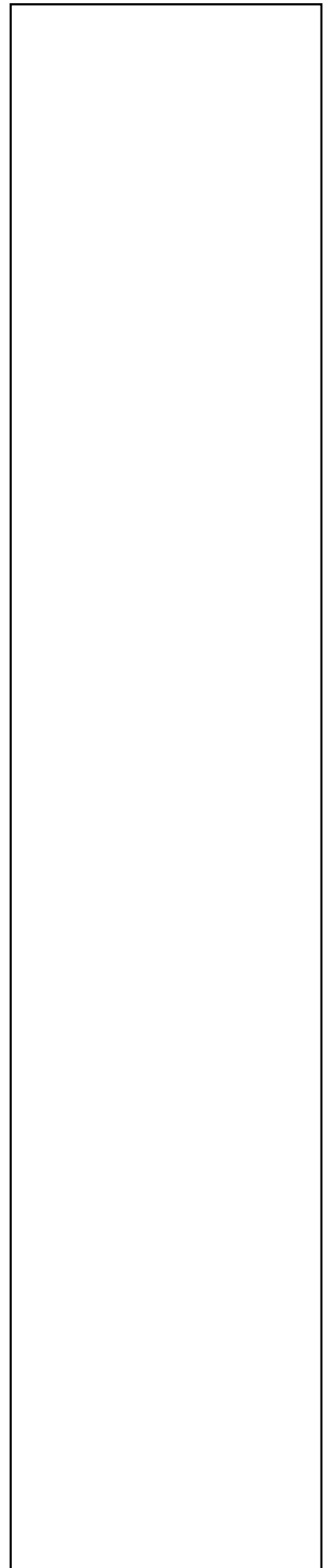

### Further information

- *Assessing and managing risks at work from skin exposure to chemical agents: Guidance for employers and health and safety specialists*  
HSG205 HSE Books 2001 ISBN 0 7176 1826 9
- *Preventing dermatitis at work: Advice for employers and employees*  
Leaflet INDG233 HSE Books 1996 (single copy free or priced packs of 15 ISBN 0 7176 1246 5)
- *Working safely with solvents: A guide to safe working practices* Leaflet INDG273 HSE Books 1998 (single copy free Web version available at [hse.gov.uk/pubns/indg273.pdf](http://hse.gov.uk/pubns/indg273.pdf))
- *Immersion and cold cleaning of engineering components* Engineering Information Sheet EIS21 HSE 1998 Web only version available at <http://www.hse.gov.uk/pubns/engindex.htm>
- *Vapour degreasing bath* Control guidance sheets G227 or G321 Web versions available at [www.coshh-essentials.org.uk/assets/live/G227.pdf](http://www.coshh-essentials.org.uk/assets/live/G227.pdf) or [www.coshh-essentials.org.uk/assets/live/G321.pdf](http://www.coshh-essentials.org.uk/assets/live/G321.pdf)

### Useful links

- HSE priced and free publications are available from HSE Books  
Tel: 01787 881165 Website: [www.hsebooks.co.uk](http://www.hsebooks.co.uk).
- For information about health and safety ring HSE's Infoline Tel: 0845 345 0055 Textphone: 0845 408 9577 e-mail: [hse.infoline@natbrit.com](mailto:hse.infoline@natbrit.com).
- Contact the British Occupational Hygiene Society (BOHS) on 01332 298101 or at [www.bohs.org](http://www.bohs.org) for lists of qualified hygienists who can help you.
- Look in the Yellow Pages under 'Health and safety consultants' and 'Health authorities and services' for 'occupational health'.
- Also see [www.nhsplus.nhs.uk](http://www.nhsplus.nhs.uk).

### Employee checklist

- Look for signs of leaks, wear and damage.
- If you find any problems, tell your supervisor. Don't just carry on working.
- Use and store your protective equipment according to instructions.
- Clear up chemical spills promptly. Absorb liquid spills in granules and dispose of them safely.
- Wash your hands after use, and before and after eating, drinking, smoking and using the lavatory.
- Never clean your hands with concentrated cleaning products, solvents or fuel.
- Check your skin regularly for dryness or soreness - tell your supervisor if these symptoms appear.
- Use skin creams provided as instructed.

This guidance is issued by the Health and Safety Executive. Following the guidance is not compulsory and you are free to take other action. But if you do follow the guidance you will normally be doing enough to comply with the law. Health and safety inspectors seek to secure compliance with the law and may refer to this guidance as illustrating good practice.